

Mercury 1500S Encoder System Interface Drawing: Short Linear Scales

THESE DRAWINGS AND SPECIFICATIONS ARE THE PROPERTY OF MicroE Systems Corp. AND SHALL NOT BE REPRODUCED OR COPIED OR USED AS THE BASIS FOR MANUFACTURE OR SALE OF APPARATUS WITHOUT EXPRESS WRITTEN AUTHORIZATION FROM MicroE Systems Corp.

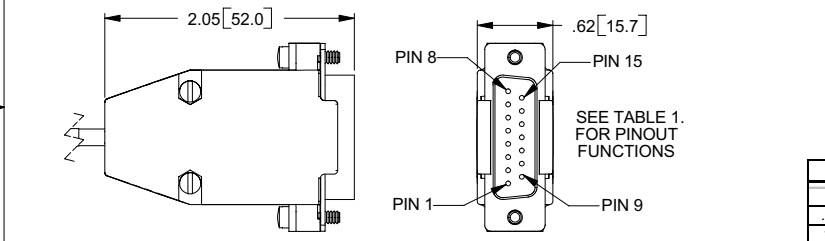
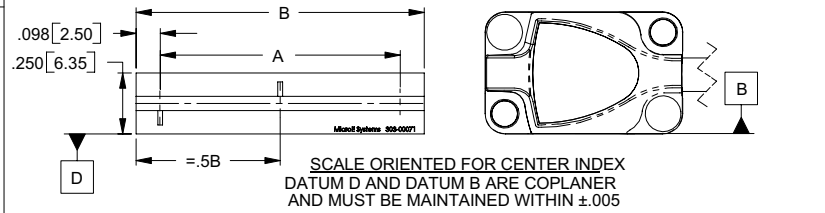
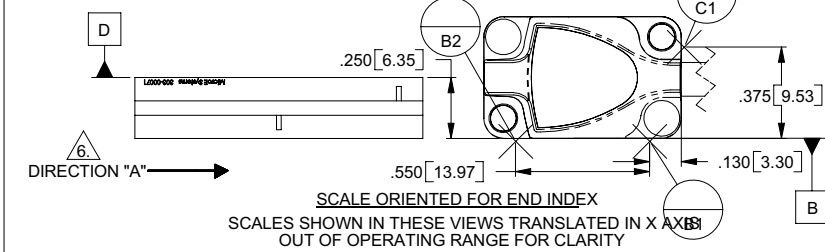

- NOTE:**
- RECOMMENDED MOUNTING HARDWARE:
2-56 OR M2 SCREWS w/ 4 FLAT WASHERS (2 ON EACH SCREW) (OD OF WASHER NOT TO EXCEED .150 [3.81]). MAX. TORQUE: 3.3 in. lbs
 - IF BENCHING PINS ARE TO BE USED, PINS MUST BE PLACED ALONG DATUM EDGES OF BOTH THE SENSOR AND THE SCALE FOR PROPER ALIGNMENT. (REFERENCE DATUMS B1, B2 AND C1 FOR SENSOR BENCHING PINS)
 - HEIGHT OF SENSOR BENCHING PINS MUST BE A MINIMUM OF .170 [4.32] IN HEIGHT FROM DATUM A.
 - HEIGHT OF SCALE BENCHING PINS NOT TO EXCEED THE THICKNESS OF THE SCALE.
 - RECOMMENDED SENSOR MOUNTING PLATE THICKNESS:
MINIMUM- 4 SCREW THREADS
MAXIMUM- ALLOW CLEARANCE TO SCALE AND SCALE MOUNTING HARDWARE (BENCHING SURFACES, CLAMPS, HUBS, ETC.)
 - WHEN SCALE MOVES IN DIRECTION "A" WITH RESPECT TO A STATIONARY READHEAD OUTPUT SIGNAL COS+/B+ (PIN 7/PIN 10) LEADS OUTPUT SIGNAL SIN+/A+ (PIN 8/PIN 5).
 - DO NOT CONNECT TO "RESERVED" PINS. SEE TABLE 1. FOR RESERVED PINS.
 - FOR SCALES ATTACHED WITH ADHESIVE TAPE (LXX-T), THE SCALE MOUNTING SURF MUST BE .006" FURTHER AWAY FROM SENSOR MOUNTING SURFACE FOR NOMINAL Z HEIGHT. DIM = .193[4.90]

TABLE 1.
15 Pin Interface
Plug Pinouts

Pin	Function (M1000)	Function (M1500S)
1	IW-	N/C
2	IW+	N/C
3	RESERVED	N/C
4	RESERVED	A-
5	RESERVED	A+
6	RESERVED	N/C
7	COS+	SIN+
8	SIN+	COS+
9	N/C	B-
10	N/C	B+
11	N/C	N/C
12	+5V	+5V
13	GND	GND
14	COS-	IW+
15	SIN-	IW-

TABLE 2.
Cable Length

(1000)	(1500S)
.5 Meter	1 Meter
1 Meter	2 Meter
2 Meter	5 Meter

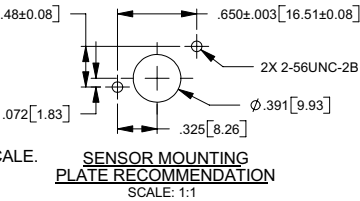

SCALE IDENTIFICATION AND SIZE

Scale	Dim A.	Dim B.
Identification #	Measured Length	Scale Length
LXX	XXmm-5mm	XXmm
ACE L30	30mm-5mm = 25mm	30mm
(max) L130	130mm-5mm = 125mm	130mm

THESE ARE EXAMPLES

REVISIONS

LTR	ECO	DESCRIPTION	DATE	APPROVED
A	---	RELEASE TO PRODUCTION	5/7/02	MF
B	879	ADDED M1000 TO DESC. UPDATED TABLE 1. SEE ECO	6/6/02	MF
C	900	UPDATED CABLE LENGTHS. ADD TABLE 2.	6/27/02	MF
D	907	UPDATED SIGNALS ON TABLE 1. SEE ECO	7/07/02	MF
E	946	UPDATED NOTE 1. ADDED MAX. TORQUE NOTE	8/14/02	MF
F	960	SNOUT DIMS TO REF. THK SCALE CORRECTED. REF.	9/24/02	MF
G	979	UPDATED TABLE 1. PIN 8 (COS+) WAS N/C. SEE ECO	11/19/02	MF
H	1426	UPDATED MODEL WITH SHRUNKEN HYBRID. ADDED NOTE B.	5/31/05	SB

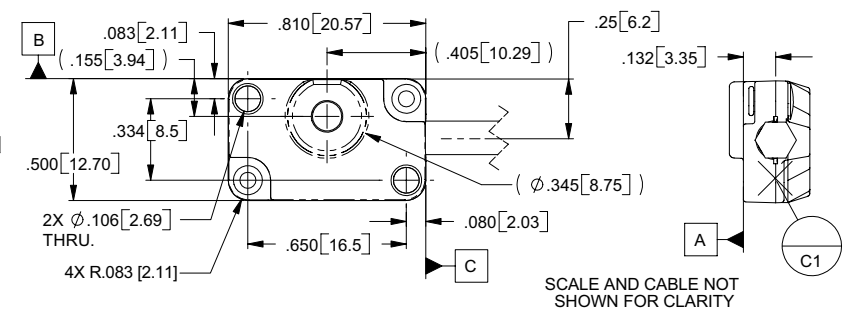
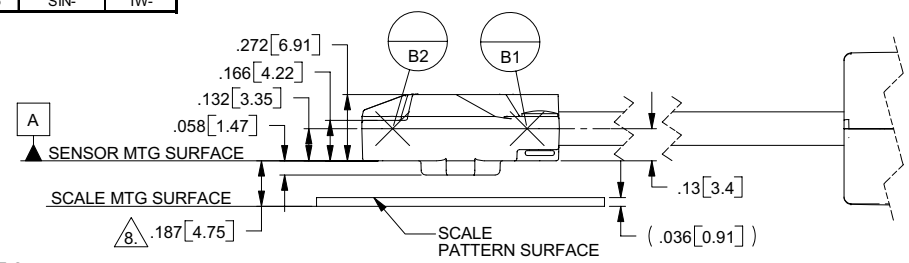
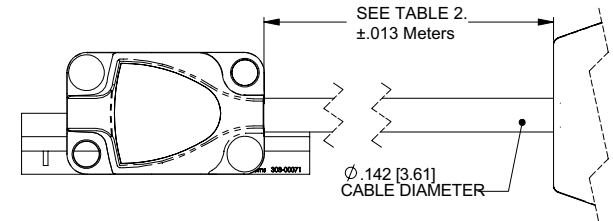

UNLESS OTHERWISE SPECIFIED APPROVALS DATE
ALL DIMENSIONS ARE IN INCHES (millimeters)
DIM. APPLY AFTER PROCESSING
DIM. APPLY AFTER PROCESSING
INTERPRET ALL GEOMETRIC TOLS.
PER ANSI Y14.5M-1994

TOLERANCES ARE:
DECIMALS: .XX [X]±.01 [25]
XXX [XX]±.005 [13]

ANGULAR: ±30 MIN.

APPROVALS	DATE
BUTURLIA	5/1/02
GRIMES	5/6/02
SKWIRA	5/6/02
FARNAM	5/6/02

UNITS: .in [mm]

MicroE Systems
PRECISION ELECTRONIC SYSTEMS

DESCRIPTION:
INTERFACE, ENCODER,
20um SHORT LINEAR,
MERCURY 1000/1500S SENSOR

SIZE: B
DWG. NO. ID-00231
SCALE: 2:1 CAD FILE: SHEET 1 OF 1

CONNECTOR NOT SHOWN IN THESE VIEWS FOR CLARITY. SEE CABLE CONNECTOR END VIEW FOR DETAILS

Mercury 1500S Encoder System Interface Drawing: Long Linear Scales

THESE DRAWINGS AND SPECIFICATIONS ARE THE PROPERTY OF MicroE Systems Corp. AND SHALL NOT BE REPRODUCED OR COPIED OR USED AS THE BASIS FOR MANUFACTURE OR SALE OF APPARATUS WITHOUT EXPRESS WRITTEN AUTHORIZATION FROM MicroE Systems Corp.

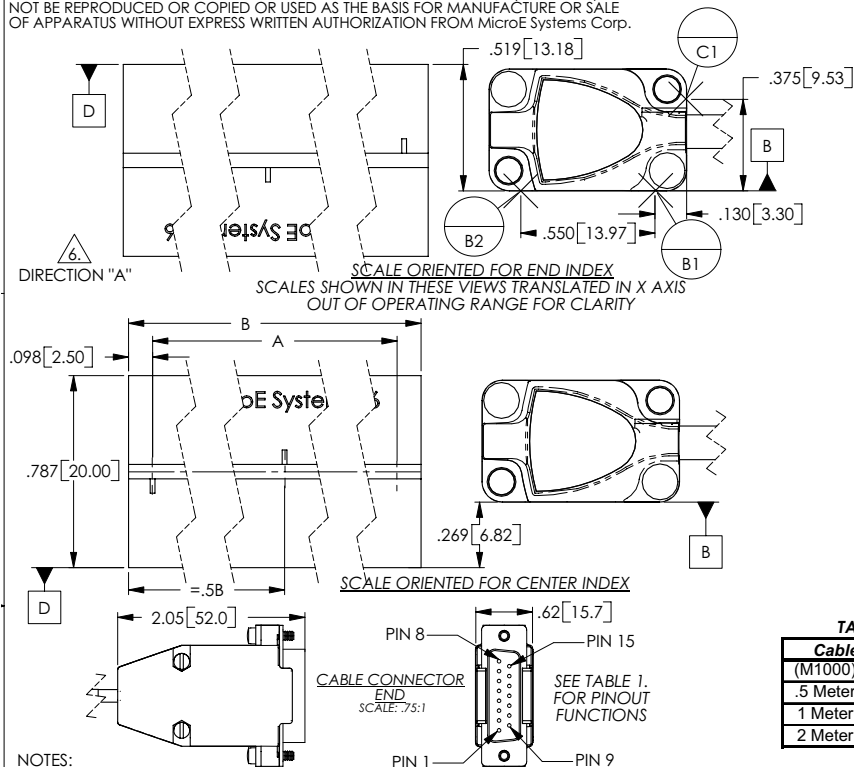

- NOTES:
- RECOMMENDED MOUNTING HARDWARE:
2-56 OR M2 SCREWS w/ 4 FLAT WASHERS (2 ON EACH SCREW)
(OD OF WASHER NOT TO EXCEED .150 [3.81])
MAX TORQUE: 3.3 in. lbs
 - IF BENCHING PINS ARE TO BE USED, PINS MUST BE PLACED ALONG DATUM EDGES OF BOTH THE SENSOR AND THE SCALE FOR PROPER ALIGNMENT. (REFERENCE DATUMS B1, B2 AND C1 FOR SENSOR BENCHING PINS)
 - HEIGHT OF SENSOR BENCHING PINS MUST BE A MINIMUM OF .170 [4.32] IN HEIGHT FROM DATUM A.
 - HEIGHT OF SCALE BENCHING PINS NOT TO EXCEED THE THICKNESS OF THE SCALE.
 - RECOMMENDED SENSOR MOUNTING PLATE THICKNESS:
MINIMUM- 4 SCREW THREADS
MAXIMUM- ALLOW CLEARANCE FOR SCALE AND SCALE MOUNTING HARDWARE (BENCHING SURFACES, CLAMPS, HUBS, ETC.)
 - WHEN SCALE MOVES IN DIRECTION "A" WITH RESPECT TO A STATIONARY READHEAD, OUTPUT SIGNAL COS+/B+ (PIN 7/PIN 10) LEADS OUTPUT SIGNAL SIN+/A+ (PIN 8/PIN 5).
 - DO NOT CONNECT TO "RESERVED" PINS. SEE TABLE 1. FOR RESERVED PINS.
 - FOR SCALES ATTACHED WITH ADHESIVE TAPE (LXX-T), THE SCALE MOUNTING SURFACE MUST BE .006" FURTHER AWAY FROM SENSOR MOUNTING SURFACE FOR NOMINAL Z HEIGHT. DIM = .255[6.48]

TABLE 1.
15 Pin Interface
Plug Pinouts

PIN	Function (M1000)	Function (M1500S)
1	IW-	N/C
2	IW+	N/C
3	RESERVED	N/C
4	RESERVED	A-
5	RESERVED	A+
6	RESERVED	N/C
7	COS+	SIN+
8	SIN+	COS+
9	N/C	B-
10	N/C	B+
11	N/C	N/C
12	*+5V	*+5V
13	GND	GND
14	COS-	IW+
15	SIN-	IW-

TABLE 2.
Cable Length

(M1000)	(1500S)
.5 Meter	1 Meter
1 Meter	2 Meter
2 Meter	5 Meter

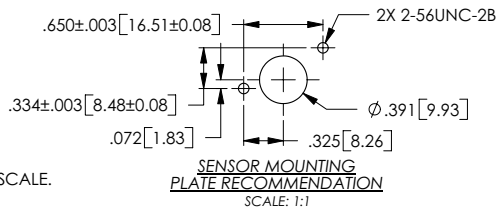

SCALE IDENTIFICATION AND SIZE

Scale Identification #	Dim. A Measured Length	Dim. B Scale Length
LXX	XXmm-5mm	XXmm
L155	155mm-5mm=155mm	155mm
(max)	2025mm-5mm=2020mm	2025mm

THESE ARE EXAMPLES

REVISIONS

LTR	ECO	DESCRIPTION	DATE	APPROVED
A	---	RELEASE TO PRODUCTION	5/7/02	MF
B	879	ADDED M1000 TO DESC., UPDATED TABLE 1. SEE ECO	6/5/02	MF
C	900	UPDATED CABLE LENGTHS, ADDED TABLE 2.	6/27/02	MF
D	907	UPDATED SIGNALS IN TABLE 1. SEE ECO	7/07/02	MF
E	946	UPDATED NOTE 1. ADDED MAX TORQUE NOTE	8/14/02	MF
F	960	SNOUT DIMS TO REF. SCALE THK TO REF.	9/24/02	MF
G	979	UPDATED TABLE 1. PIN 8 (COS+) WAS N/C. SEE ECO	11/19/02	MF
H	1426	UPDATED MODEL WITH SHRUNKEN HYBRID. ADDED NOTE 8.	5/25/05	SB
I	1498	REVERSED PINS 9 & 15 IN CABLE CONNECTOR DETAIL.	10/28/05	SB

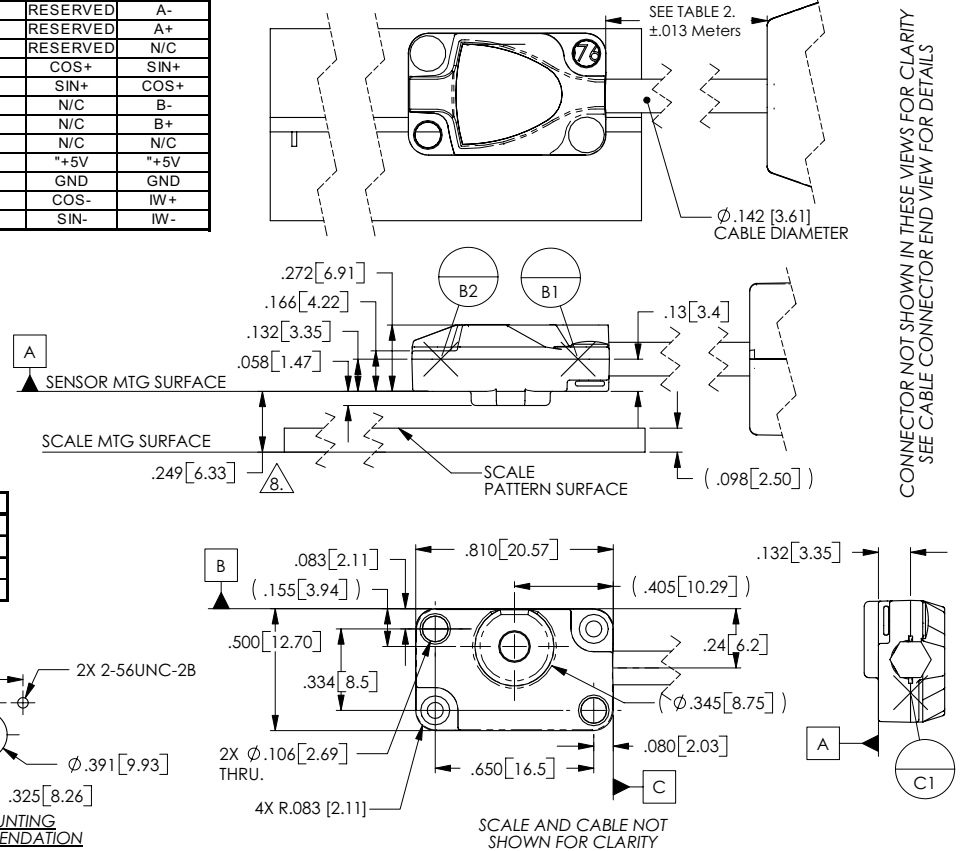

UNLESS OTHERWISE SPECIFIED ALL DIMENSIONS ARE IN INCHES DIM. APPLY AFTER PROCESSING INTERPRET ALL GEOMETRIC TOLS. PER ANSI Y14.5M-1994 TOLERANCES ARE: DECIMALS: .XX ± .01 .XXX ± .005 ANGULAR: ±50 MIN.

APPROVALS	DATE
DRAWN: S.BUTURLIA	5/3/02
CHECKED:	
ENGRG: DON GRIMES	5/6/02
DRAWING: MIKE SKWIRA	5/6/02
QA: JACK FARNAM	5/6/02

GSI MicroE Systems Division of GSI
8 Erie Drive
Natick, MA 01760

DESCRIPTION:
INTERFACE, ENCODER,
20um LONG LINEAR,
MERCURY 1000/1500S SENSOR

SIZE: DWGS. NO. ID-00232
SCALE: 2:1 CAD FILE: SHEET 1 OF 1

Mercury 1500S Encoder System Interface Drawing: Rotary Scale with Hub

THESE DRAWINGS AND SPECIFICATIONS ARE THE PROPERTY OF MicroE Systems Corp. AND SHALL NOT BE REPRODUCED OR COPIED OR USED AS THE BASIS FOR MANUFACTURE OR SALE OF APPARATUS WITHOUT EXPRESS WRITTEN AUTHORIZATION FROM MicroE Systems Corp.

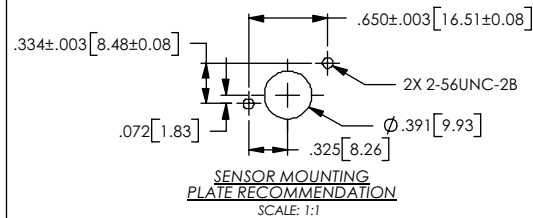
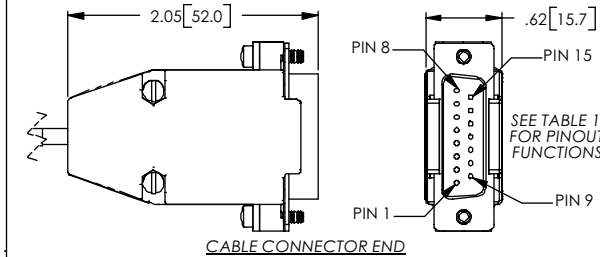

TABLE 1.
15 Pin Interface Plug Pinouts

Pin	Function (M1000)	Function (M1500S)
1	IW-	N/C
2	IW+	N/C
3	RESERVED	N/C
4	RESERVED	A-
5	RESERVED	A+
6	RESERVED	N/C
7	COS+	SIN+
8	SIN+	COS+
9	N/C	B-
10	N/C	B+
11	N/C	N/C
12	+5V	+5V
13	GND	GND
14	COS-	IW+
15	SIN-	IW-

- NOTE:
- RECOMMENDED MOUNTING HARDWARE:
2-56 OR M2 SCREWS w/ 4 FLAT WASHERS (2 ON EACH SCREW)
(OD OF WASHER NOT TO EXCEED .150 [3.81])
MAX TORQUE: 3.3 in. lbs
 - IF BENCHING PINS ARE TO BE USED, PINS MUST BE PLACED ALONG DATUM EDGES OF SENSOR FOR PROPER ALIGNMENT.
(REFERENCE DATUMS B1, B2 AND C1).
 - HEIGHT OF SENSOR BENCHING PINS MUST BE A MINIMUM OF .170 [4.32] IN HEIGHT FROM DATUM A.
 - RECOMMENDED SENSOR MOUNTING PLATE THICKNESS:
MINIMUM- 4 SCREW THREADS
MAXIMUM- ALLOW CLEARANCE FOR SCALE AND SCALE MOUNTING HARDWARE (BENCHING SURFACES, CLAMPS, HUBS, ETC.)
 - WHEN SCALE MOVES IN DIRECTION "A" WITH RESPECT TO A STATIONARY READHEAD, OUTPUT SIGNAL COS+/B+ (PIN 7/PIN 10) LEADS OUTPUT SIGNAL SIN+/A+ (PIN 8/PIN 5).
 - DO NOT CONNECT TO "RESERVED" PINS. SEE TABLE 1. FOR RESERVED PINS.

TABLE 2.
Cable Length

(1000)	(1500S)
.5 Meter	1 Meter
1 Meter	2 Meter
2 Meter	5 Meter

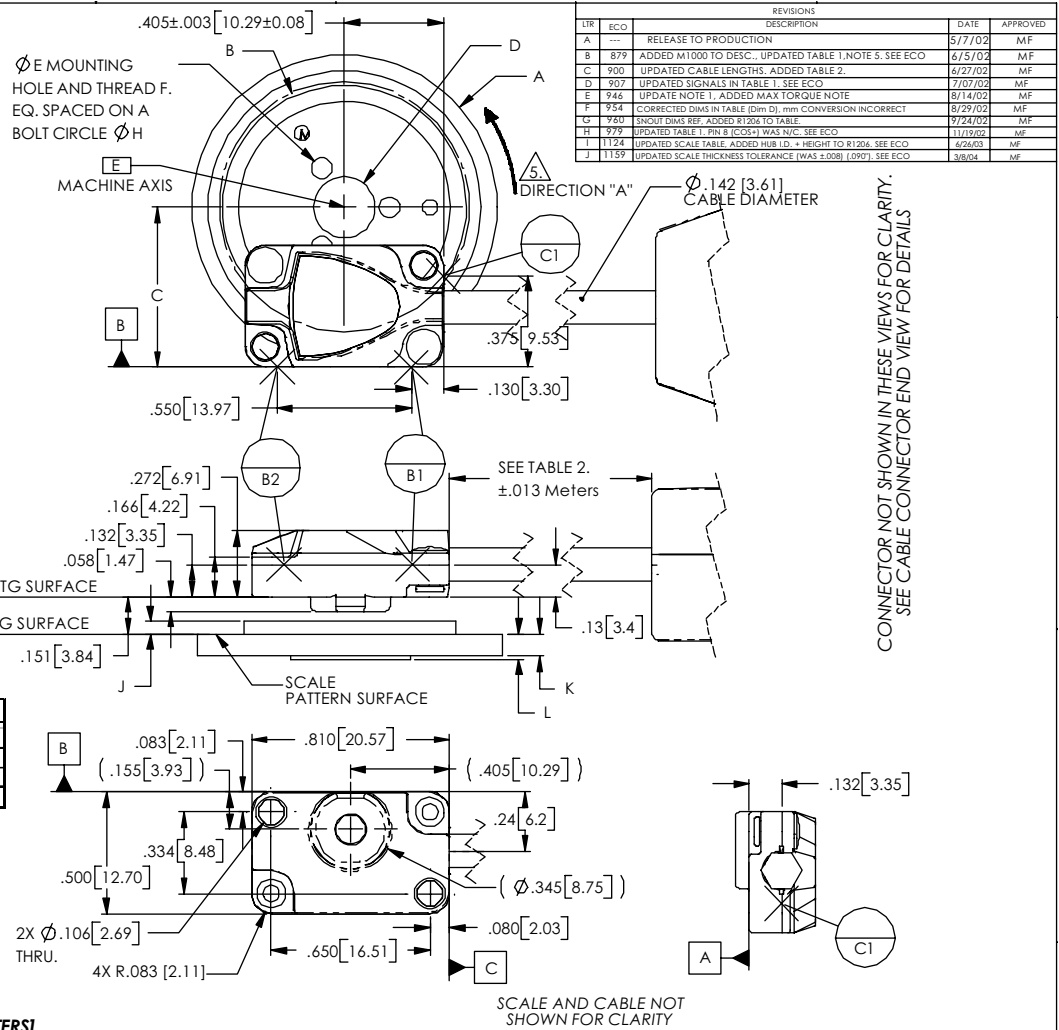

REVISIONS

LTR	ECO	DESCRIPTION	DATE	APPROVED
A	---	RELEASE TO PRODUCTION	5/7/02	MF
B	879	ADDED M1000 TO DESC., UPDATED TABLE 1, NOTE 5. SEE ECO	6/5/02	MF
C	900	UPDATED CABLE LENGTHS. ADDED TABLE 2.	6/27/02	MF
D	907	UPDATED SIGNALS IN TABLE 1. SEE ECO	7/07/02	MF
E	946	UPDATE NOTE 1. ADDED MAX TORQUE NOTE	8/14/02	MF
F	954	CORRECTED DIMS IN TABLE (Dim D), mm CONVERSION INCORRECT	8/29/02	MF
G	980	ENCUT DIMS REF. ADDED #1200 TO TABLE	11/24/02	MF
H	979	UPDATED TABLE 1. (PIN 8 ECOS+) WAS N/C. SEE ECO	11/19/02	MF
I	1124	UPDATED SCALE TABLE. ADDED HUB I.D. + HEIGHT TO R1200. SEE ECO	6/26/03	MF
J	1159	UPDATED SCALE THICKNESS TOLERANCE [WAS ±.008] (.097). SEE ECO	3/8/04	MF

CONNECTOR NOT SHOWN IN THESE VIEWS FOR CLARITY.
SEE CABLE CONNECTOR END VIEW FOR DETAILS

SCALE IDENTIFICATION AND SIZE. DIMENSIONS IN INCHES [MILLIMETERS]

Scale	Counts/Rev	Dim. A Scale O.D.	Scale I.D.	Dim. B Optical Dia.	Dim. C Mounting Dim.	Dim. D Hub I.D.	Dim. E Mounting Hole Dia.	Thread F	Dim. H Bolt Circle	Dim. J Hub Height	Dim. K Scale Thickness	Dim. L Hub Relief
R1206	1,650	0.472 [12.00]	.250+/- .005 [6.35+/- .13]	0.413 [10.50]	0.348+/- .002 [8.84+/- .05]	0.1253+ .0005/- .0000 [3.182+ .013/- .000]	N/A	N/A	N/A	0.040 [1.02]	.036+/- .002 [.91+/- .05]	0.045 [1.14]
R1910	2,500	0.750 [19.05]	.375+/- .005 [9.53+/- .013]	0.627 [15.92]	0.454+/- .002 [11.53+/- .05]	0.1253+ .0005/- .0000 [3.182+ .013/- .000]	0.047 [1.19]	0-80 [6.35]	0.250 [6.35]	0.040 [1.02]	.090+/- .004 [2.29+/- .10]	0.105 [2.67]
R3213	4,096	1.250 [31.75]	.500+/- .005 [12.70+/- .013]	1.027 [26.08]	0.654+/- .002 [16.62+/- .05]	0.2503+ .0005/- .0000 [6.357+ .013/- .000]	0.070 [1.78]	2-56 [9.40]	0.370 [9.40]	0.050 [1.27]	.090+/- .004 [2.29+/- .10]	0.105 [2.67]
R5725	8,192	2.250 [57.15]	1.000+/- .005 [25.40+/- .013]	2.053 [52.15]	1.168+/- .002 [29.66+/- .05]	0.5003+ .0005/- .0000 [12.707+ .013/- .000]	0.136 [3.45]	8-32 [19.05]	0.750 [19.05]	0.060 [1.52]	.090+/- .004 [2.29+/- .10]	0.105 [2.67]
R10851	16,384	4.250 [107.95]	2.000+/- .005 [50.80+/- .013]	4.106 [104.30]	2.194+/- .002 [55.73+/- .05]	1.0003+ .0005/- .0000 [25.408+ .013/- .000]	0.136 [3.45]	8-32 [19.05]	1.375 [34.93]	0.080 [2.03]	.090+/- .004 [2.29+/- .10]	0.105 [2.67]

UNLESS OTHERWISE SPECIFIED
ALL DIMENSIONS ARE IN INCHES [millimeters]
DIM. APPLY AFTER PROCESSING
INTERPRET ALL GEOMETRIC TOLS. PER ANSI Y14.5M-1994

TOLERANCES ARE:
DECIMALS: .XX [X]±.01 [25]
XXX [XX]±.005 [13]
ANGULAR: ±30 MIN.

APPROVALS

DATE	APPROVED
5/6/02	S. BUTURLIA
5/6/02	DON GRIMES
5/6/02	MIKE SKWIRA
5/6/02	JACK FARNAM

DESCRIPTION: INTERFACE, ENCODER, 20um ROTARY w/HUB, MERCURY 1000/1500S SENSOR

UNITS: .in [mm]

Mercury 1500H Encoder System

Interface Drawing: Short linear Scale

THESE DRAWINGS AND SPECIFICATIONS ARE THE PROPERTY OF MicroE Systems Corp. AND SHALL NOT BE REPRODUCED OR COPIED OR USED AS THE BASIS FOR MANUFACTURE OR SALE OF APPARATUS WITHOUT EXPRESS WRITTEN AUTHORIZATION FROM MicroE Systems Corp.

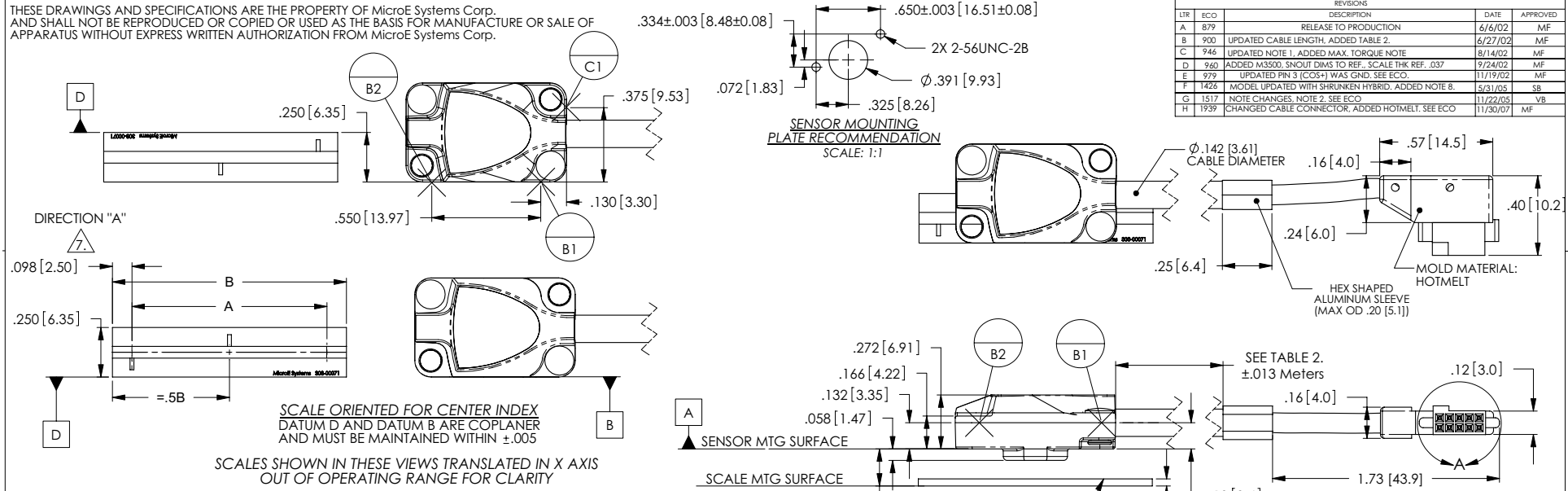

- NOTE:**
- RECOMMENDED MOUNTING HARDWARE:
2-56 OR M2 SCREWS w/ 4 FLAT WASHERS (2 ON EACH SCREW) (OD OF WASHER NOT TO EXCEED .150 [3.81]).
MAX. TORQUE: 3.3 in. lbs
 - FOR APPLICATIONS USING THE SMARTPRECISION ELECTRONICS THIS CONNECTOR (FCI p/n 87012-605 or SAMTEC p/n SFM-105-03-S-D) IS INSIDE THE ENCLOSURE (see Interface drawings). ADDITIONAL STRAIN RELIEF MUST BE PROVIDED IF MICROE SUPPLIED ELECTRONICS IS NOT USED.
RECOMMENDED MATING CONNECTOR: FCI p/n 87407-105/SAMTEC p/n TFM series OR EQUIVALENT.
 - IF BENCHING PINS ARE TO BE USED, PINS MUST BE PLACED ALONG DATUM EDGES OF BOTH THE SENSOR AND THE SCALE FOR PROPER ALIGNMENT. (REFERENCE DATUMS B1, B2 AND C1 FOR SENSOR BENCHING PINS)
 - HEIGHT OF SENSOR BENCHING PINS MUST BE A MINIMUM OF .170 [4.32] IN HEIGHT FROM DATUM A.
 - HEIGHT OF SCALE BENCHING PINS NOT TO EXCEED THE THICKNESS OF THE SCALE.
 - RECOMMENDED SENSOR MOUNTING PLATE THICKNESS:
MINIMUM- 4 SCREW THREADS
MAXIMUM- ALLOW CLEARANCE TO SCALE AND SCALE MOUNTING HARDWARE (BENCHING SURFACES, CLAMPS, HUBS, ETC.)

TABLE 2.

Cable Length	
(1500H)	(2000/3000/3500)
1 Meter	.5 Meter
2 Meter	1 Meter
5 Meter	2 Meter

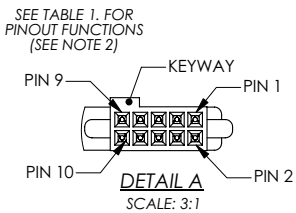

SCALE IDENTIFICATION AND SIZE

Scale Identification #	Dim A. Measured Length	Dim B. Scale Length
LXX	XXmm-5mm	XXmm
L30	30mm-5mm = 25mm	30mm
(max) L130	130mm-5mm = 125mm	130mm

THESE ARE EXAMPLES

- WHEN SCALE MOVES IN DIRECTION "A" WITH RESPECT TO A STATIONARY READHEAD, OUTPUT SIGNAL COS+/B+ (PIN 5/PIN 9) LEADS OUTPUT SIGNAL SIN+/A+ (PIN 1/PIN 5).
- FOR SCALES ATTACHED WITH ADHESIVE TAPE (LXX-T), THE SCALE MOUNTING SURFACE MUST BE .006" FURTHER AWAY FROM SENSOR MOUNTING SURFACE FOR NOMINAL Z HEIGHT. DIM = .193[4.90]

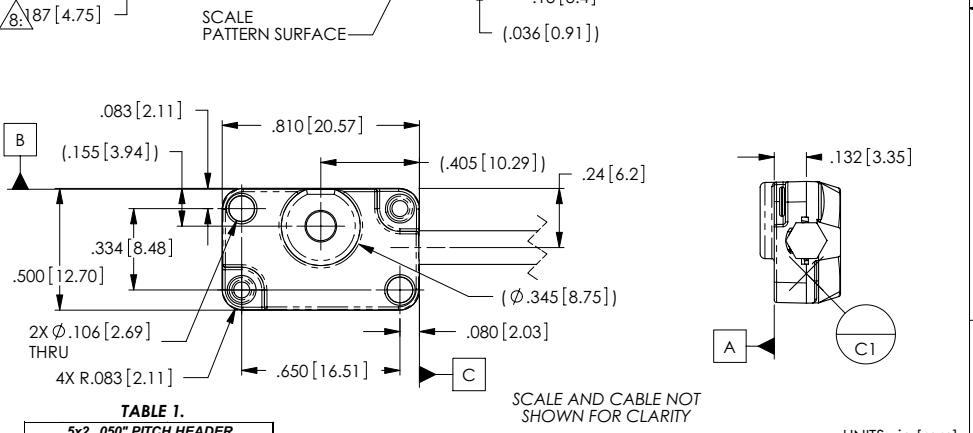

TABLE 1.

5x2.050" PITCH HEADER		
PIN	Function (2000/3000/3500)	Function (1500H)
1	SIN-	SIN+
2	INDEX WINDOW-	INDEX WINDOW-
3	SIN-	COS+
4	GND	GND
5	COS+	A+
6	INDEX WINDOW+	INDEX WINDOW+
7	COS-	A-
8	+5V	+5V
9	N/C	B+
10	N/C	B-

UNLESS OTHERWISE SPECIFIED ALL DIMENSIONS ARE IN INCHES (millimeters) DIM. APPLY AFTER PROCESSING INTERPRET ALL GEOMETRIC TOLS. PER ANSI Y14.5M-1994

TOLERANCES ARE:
DECIMALS: .XX [X] ±.01 [25] ±.005 [1.3]
ANGULAR: ±.30 MIN.

APPROVALS

DATE	APPROVED
4/18/01	S. BUTURLIA (CHECKED)
6/5/02	DON GRIMES (ENGRG.)
6/6/02	M. SKWIRA (PREFENG)
6/6/02	J. FARNAM (QA)

UNITS: .in [mm]

GSI MicroE Systems[®]
MicroE Systems
Division of GSI
8 Erie Drive
Natick, MA 01760

DESCRIPTION:
INTERFACE, ENCODER, 20um, SHORT LINEAR, CABLE OUT, MERCURY 1500H/2000/3000/3500 SENSOR

SEE DWG. NO. ID-00200
SCALE: 2:1 CAD FILE: SHEET 1 OF 1

Mercury 1500H Encoder System Interface Drawing: Long Linear Scale

THESE DRAWINGS AND SPECIFICATIONS ARE THE PROPERTY OF MicroE Systems Corp. AND SHALL NOT BE REPRODUCED OR COPIED OR USED AS THE BASIS FOR MANUFACTURE OR SALE OF APPARATUS WITHOUT EXPRESS WRITTEN AUTHORIZATION FROM MicroE Systems Corp.

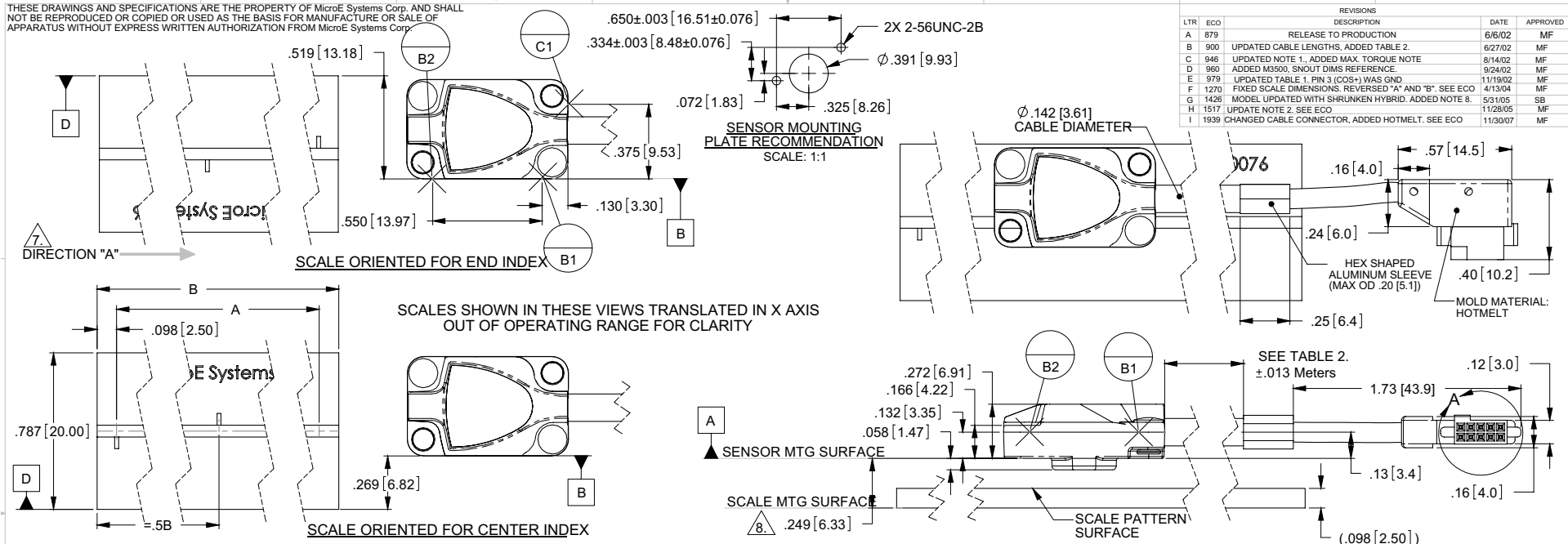

REVISIONS				
LTR	ECO	DESCRIPTION	DATE	APPROVED
A	879	RELEASE TO PRODUCTION	6/6/02	MF
B	900	UPDATED CABLE LENGTHS, ADDED TABLE 2.	9/27/02	MF
C	946	UPDATED NOTE 1, ADDED MAX. TORQUE NOTE	8/14/02	MF
D	960	ADDED M3500, SNOOT DIMS REFERENCE.	9/24/02	MF
E	979	UPDATED TABLE 1, PIN 3 (COS+) WAS GND	11/19/02	MF
F	1270	FIXED SCALE DIMENSIONS, REVERSED "A" AND "B". SEE ECO	4/13/04	MF
G	1426	MODEL UPDATED WITH SHRUNKEN HYBRID, ADDED NOTE 8.	5/31/05	SS
H	1517	UPDATE NOTE 2. SEE ECO	11/28/05	MF
I	1939	CHANGED CABLE CONNECTOR, ADDED HOTMELT. SEE ECO	11/30/07	MF

- NOTES:**
- RECOMMENDED MOUNTING HARDWARE: 2-56 OR M2 SCREWS w/ 4 FLAT WASHERS (2 ON EACH SCREW) (OD OF WASHER NOT TO EXCEED .150 [3.81]). MAX. TORQUE: 3.3 in. lbs
 - FOR APPLICATIONS USING THE SMARTPRECISION ELECTRONICS THIS CONNECTOR (FCI p/n 87012-605 or SAMTEC p/n SFM-105-03-S-D) IS INSIDE THE ENCLOSURE (see Interface drawings). ADDITIONAL STRAIN RELIEF MUST BE PROVIDED IF MICROE SUPPLIED ELECTRONICS IS NOT USED. RECOMMENDED MATING CONNECTOR: FCI p/n 87407-105/SAMTEC p/n TFM SERIES OR EQUIVALENT.
 - IF BENCHING PINS ARE TO BE USED, PINS MUST BE PLACED ALONG DATUM EDGES OF BOTH THE SENSOR AND THE SCALE FOR PROPER ALIGNMENT SEE TABLE 1, FOR PINOUT FUNCTIONS (SEE NOTE 2)
 - HEIGHT OF SENSOR BENCHING PINS MUST BE A MINIMUM OF .170 [4.32] IN HEIGHT FROM DATUM A.
 - HEIGHT OF SCALE BENCHING PINS NOT TO EXCEED THE THICKNESS OF THE SCALE.
 - RECOMMENDED SENSOR MOUNTING PLATE THICKNESS: MINIMUM- 4 SCREW THREADS MAXIMUM- ALLOW CLEARANCE TO SCALE AND SCALE MOUNTING HARDWARE (BENCHING SURFACES, CLAMPS, HUBS, ETC.)

TABLE 2.

Cable Length	
(1500H)	(2000/3000/3500)
1 Meter	.5 Meter
2 Meter	1 Meter
5 Meter	2 Meter

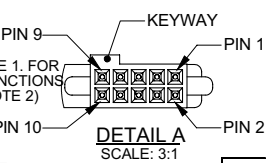

TABLE 1.

5x2, .050" PITCH HEADER		
PIN	Function	Function
(2000/3000/3500) (1500H)		
1	SIN+	SIN+
2	INDEX WINDOW-	INDEX WINDOW-
3	SIN-	COS+
4	GND	GND
5	COS+	A+
6	INDEX WINDOW+	INDEX WINDOW+
7	COS-	A-
8	+5V	+5V
9	N/C	B+
10	N/C	B-

UNLESS OTHERWISE SPECIFIED
ALL DIMENSIONS ARE IN INCHES (millimeters)
DIM. APPLY AFTER PROCESSING
INTERPRET ALL GEOMETRIC TOLS.
PER ANSI Y14.5M-1994

TOLERANCES ARE:
DECIMALS: .XX (XX: 01 [25])
.XXX .XX2 .005 [13]

ANGULAR: ±30 MIN.

APPROVALS	DATE
DRAWN S. BUTURLIA CHECKED	4/18/01
ENGRG. DON GRIMES	6/5/02
MFG ENG. M. SKWIRA QA J. FARNAM	6/6/02

GSI MicroE Systems
Division of GSI
8 Erie Drive
Natick, MA 01760

DESCRIPTION:
INTERFACE, ENCODER, 20um,
LONG LINEAR, CABLE OUT, MERCURY
1500H/2000/3000/3500 SENSOR

SIZE DWG. NO. ID-00201
SCALE: 2:1 CAD FILE SHEET 1 OF 1

- WHEN SCALE MOVES IN DIRECTION "A" WITH RESPECT TO A STATIONARY READHEAD, OUTPUT SIGNAL COS+B+ (PIN 5/PIN 9) LEADS OUTPUT SIGNAL SIN+A+ (PIN 1/PIN 5).
- FOR SCALES ATTACHED W/ADHESIVE TAPE (LXX-T), THE SCALE MOUNTING SURFACE MUST BE .006" FURTHER AWAY FROM SENSOR MOUNTING SURFACE FOR NOMINAL Z HEIGHT. DIM = .255[6.48]

THESE ARE EXAMPLES

SCALE IDENTIFICATION AND SIZE

Scale	Dim A.	Dim B.
Identification #	Measured Length	Scale Length
LXX	XXmm-5mm	XXmm
L155	155mm-5mm = 150mm	155mm
(max) L2025	2025mm-5mm = 2020mm	2025mm

Mercury 1500H Encoder System Interface Drawing: Rotary Scale with Hub

THESE DRAWINGS AND SPECIFICATIONS ARE THE PROPERTY OF MicroE Systems Corp. AND SHALL NOT BE REPRODUCED OR COPIED OR USED AS THE BASIS FOR MANUFACTURE OR SALE OF APPARATUS WITHOUT EXPRESS WRITTEN AUTHORIZATION FROM MicroE Systems Corp.

NOTE:

1. RECOMMENDED MOUNTING HARDWARE:
2-56 OR M2 SCREWS w/ 4 FLAT WASHER (2 ON EACH SCREW)
(OD OF WASHERS NOT TO EXCEED .150 [3.81]).
MAX TORQUE: 3.3 in. lbs
2. FOR APPLICATIONS USING THE SMARTPRECISION ELECTRONICS THIS CONNECTOR (FCI p/n 87012-605 or SAMTEC p/n SFM-105-03-S-D) IS INSIDE THE ENCLOSURE (see Interface drawings). ADDITIONAL STRAIN RELIEF MUST BE PROVIDED IF MICROE SUPPLIED ELECTRONICS IS NOT USED. RECOMMENDED MATING CONNECTOR: FCI p/n 87407-105/SAMTEC p/n TFM SERIES OR EQUIVALENT.
3. IF BENCHING PINS ARE TO BE USED, PINS MUST BE PLACED ALONG DATUM EDGES OF SENSOR FOR PROPER ALIGNMENT. (REFERENCE DATUMS B1, B2 AND C1).
4. HEIGHT OF SENSOR BENCHING PINS MUST BE A MINIMUM OF .170 [4.32] IN HEIGHT FROM DATUM A.
5. RECOMMENDED SENSOR MOUNTING PLATE THICKNESS:
MINIMUM- 4 SCREW THREADS
MAXIMUM- ALLOW CLEARANCE TO SCALE AND SCALE MOUNTING HARDWARE (BENCHING SURFACES, CLAMPS, HUBS, ETC.)

6. WHEN SCALE MOVES IN DIRECTION "A" WITH RESPECT TO A STATIONARY READHEAD, OUTPUT SIGNAL COS+/B+ (PIN 5/PIN 9) LEADS OUTPUT SIGNAL SIN+/A+ (PIN 1/PIN 5).

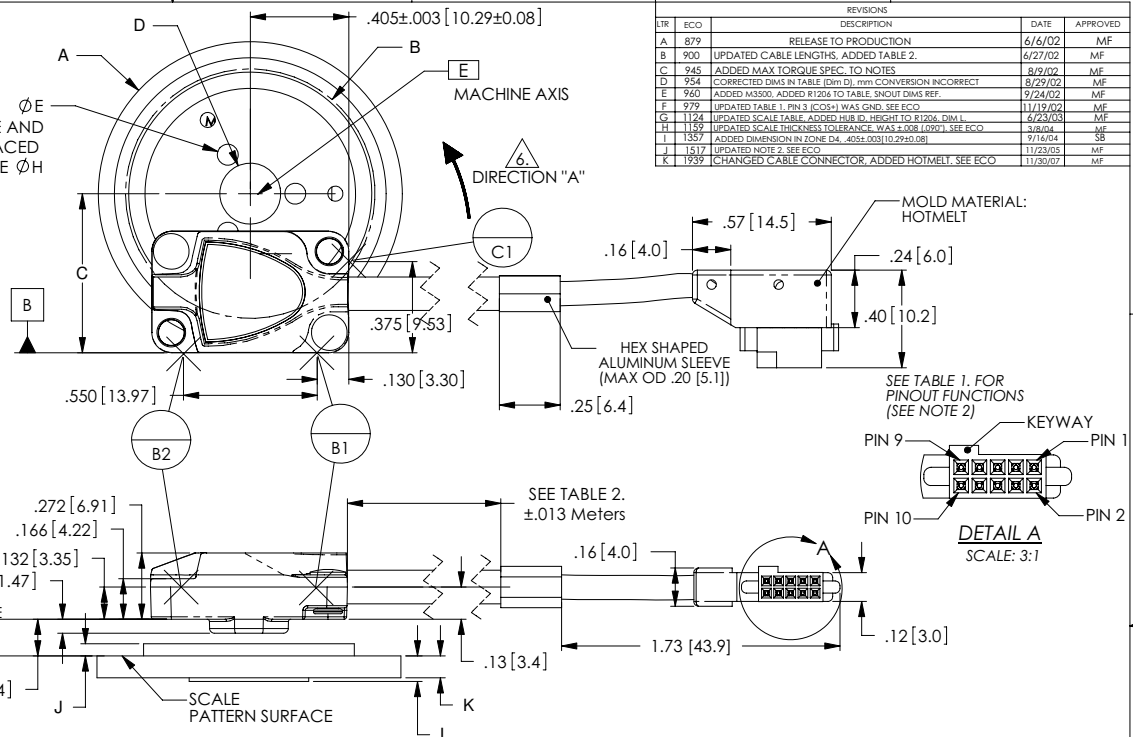

REV	ECO	DESCRIPTION	DATE	APPROVED
A	879	RELEASE TO PRODUCTION	6/6/02	MF
B	900	UPDATED CABLE LENGTHS, ADDED TABLE 2.	6/27/02	MF
C	845	ADDED MAX TORQUE SPEC. TO NOTES	8/29/02	MF
D	954	CORRECTED DIMS IN TABLE (Dim D), mm CONVERSION INCORRECT	8/29/02	MF
E	960	ADDED M3000, ADDED R1206 TO TABLE, SNOOT DIMS REF.	9/24/02	MF
F	979	UPDATED TABLE 1, PIN 3 (COS+) WAS GND, SEE ECO	11/19/02	MF
G	1124	UPDATED SCALE TABLE, ADDED HUB ID, HEIGHT TO R1206, DIM L	6/23/03	MF
H	1159	UPDATED SCALE THICKNESS TOLERANCE, WAS +0.08 [2.03], SEE ECO	3/8/04	MF
J	1357	ADDED DIMENSION IN ZONE D4, 405±.003 [10.29±0.08]	9/16/04	SB
K	1517	UPDATED NOTE 2, SEE ECO	11/23/05	MF
L	1939	CHANGED CABLE CONNECTOR, ADDED HOTMELT, SEE ECO	11/30/07	MF

TABLE 2.
Cable Length

	(1500H)	(2000/3000/3500)
1 Meter	.5 Meter	
2 Meter	1 Meter	
5 Meter	2 Meter	

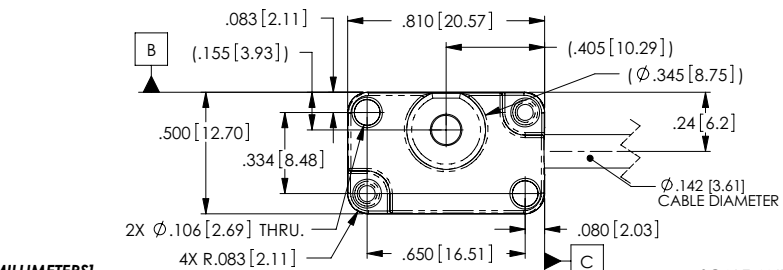
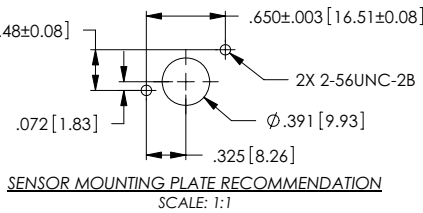

TABLE 1.
5x2, .050" PITCH HEADER

PIN	Function (2000/3000/3500)	Function (1500H)
1	SIN+	SIN+
2	INDEX WINDOW-	INDEX WINDOW-
3	SIN-	COS+
4	GND	GND
5	COS+	A+
6	INDEX WINDOW+	INDEX WINDOW+
7	COS-	A-
8	+5V	+5V
9	N/C	B+
10	N/C	B-

SCALE IDENTIFICATION AND SIZE. DIMENSIONS IN INCHES [MILLIMETERS]

Scale Identification	Counts/Rev	Dim. A Scale O.D.	Scale I.D.	Dim. B Optical Dia.	Dim. C Mounting Dim.	Dim. D. Hub I.D.	Dim. E. Mounting Hole Dia.	Thread F	Dim. H. Bolt Circle	Dim. J. Hub Height	Dim. K. Scale Thickness	Dim. L. Hub Relief
R1206	1,650	0.472 [12.00]	.250+/- .005 [6.35+/- .13]	0.413 [10.50]	0.348+/- .002 [8.84+/- .05]	0.1253+ .0005/- .0000 [3.182+ .013/- .000]	N/A	N/A	N/A	0.040 [1.02]	.036+/- .002 [0.91+/- .05]	0.045 [1.14]
R1910	2,500	0.750 [19.05]	.375+/- .005 [9.53+/- .13]	0.627 [15.92]	0.454+/- .002 [11.53+/- .05]	0.1253+ .0005/- .0000 [3.182+ .013/- .000]	0.047 [1.19]	0-80 [6.35]	0.250 [6.35]	0.040 [1.02]	.090+/- .004 [2.29+/- .10]	0.105 [2.67]
R3213	4,096	1.250 [31.75]	.500+/- .005 [12.70+/- .13]	1.027 [26.08]	0.654+/- .002 [16.62+/- .05]	0.2503+ .0005/- .0000 [6.357+ .013/- .000]	0.070 [1.78]	2-56 [9.40]	0.370 [9.40]	0.050 [1.27]	.090+/- .004 [2.29+/- .10]	0.105 [2.67]
R5725	8,192	2.250 [57.15]	1.000+/- .005 [25.40+/- .13]	2.053 [52.15]	1.168+/- .002 [29.66+/- .05]	0.5003+ .0005/- .0000 [12.707+ .013/- .000]	0.136 [3.45]	8-32 [19.05]	0.750 [19.05]	0.060 [1.52]	.090+/- .004 [2.29+/- .10]	0.105 [2.67]
R10851	16,384	4.250 [107.95]	2.000+/- .005 [50.80+/- .13]	4.106 [104.30]	2.194+/- .002 [55.73+/- .05]	1.0003+ .0005/- .0000 [25.408+ .013/- .000]	0.136 [3.45]	8-32 [19.05]	1.375 [34.93]	0.080 [2.03]	.090+/- .004 [2.29+/- .10]	0.105 [2.67]

SCALE AND CABLE NOT SHOWN FOR CLARITY

UNLESS OTHERWISE SPECIFIED, ALL DIMENSIONS ARE IN INCHES [millimeters]. DIM. APPLY AFTER PROCESSING. INTERPRET ALL GEOMETRIC TOLS. PER ANSI Y14.5M-1994.

TOLERANCES ARE:
DECIMALS: .XX [X]±.01 [25]
XXX [XX]±.003 [13]

APPROVALS: DRAWN S.BUTURLIA, CHECKED [Signature], ENGRG. DON GRIMES, MFG ENGR. M.SKWIRA, QA J.FARNAM

DATE: 4/20/01, 6/5/02, 6/6/02, 6/6/02

ANGULAR: ±30 MIN.

UNITS: in [mm]

GSI MicroE Systems
8 Erie Drive
Natick, MA 01760

DESCRIPTION: INTERFACE, ENCODER, 20um, ROTARY w/HUB, CABLE OUT, MERCURY 1500H/2000/3000/3500 SENSOR

REV. K
DWG. NO. ID-00202
SCALE: 2:1
CAD FILE: [Icon]